

Expertise  
in High Technology Materials

# Brandenburger GFRP Pipe Lining

## The Brandenburger system

Brandenburger has developed a sewer rehabilitation system in which all elements harmonize perfectly, from the production of GFRP pipe liner made of light-curing resins and other high-grade materials, the development and production of the required UV light equipment to service for the expert liner installation.

This closed system from one single manufacturer is prerequisite for safe and durable renovation of damaged sewers.

### Brandenburger utilises high quality

The company has a quality management system and is DIN EN ISO 9001:2000 certified.

**RAL quality seal:** RAL quality seal for sewer construction S27.18 - Brandenburger liner S14.05 - Brandenburger light-curing hat profile

### International approvals

**Germany:**  
No. Z-42.3-330 DIBt, Deutsches Institut für Bautechnik (German Institute for Construction Technology)

**Switzerland:**  
QuiK, No. 2004-12-4422-01, Qualitätssicherung bei Instandsetzungs- und Sanierungsarbeiten an nichtbegehbaren Kanalisationen (Quality Assurance for Restoration and Rehabilitation Work in Non-accessible Sewers)

**France:**  
Avis Technique Nr. 17/06-182; CSTB, Wissenschaftliches und technisches Zentrum für Bauwesen (Scientific and technical centre for the construction industry), [www.cstb.fr](http://www.cstb.fr)

**Denmark:**  
NO DIG Kontrolordning for Ledningsrenovering (Inspection regulation on pipe line rehabilitation) No. B 1308



- GFRP pipe liner production
- UV light curing equipment
- Service/Application technology

## Brandenburger

Brandenburger Liner GmbH & Co. KG  
Taubensuhlstraße 6  
D - 76829 Landau/Pfalz  
Tel. +49 63 41 / 51 04-0  
Fax +49 63 41 / 51 04-155  
[info@brandenburger.de](mailto:info@brandenburger.de)

# “Brandenburger pipe liner with glass-fibre reinforcement – high-grade material for many applications”



Where highest stability, excellent chemical durability, and extreme longevity are demanded of industrial materials, glass-fibre reinforced plastics (GFRP) find employment. Brandenburger is specialised in the processing of high-quality material for around 70 years and has successfully put GFRP composite materials to use in modern trenchless sewer rehabilitation since the early 1990s.

GFRP is a “programmable” material. The glass fibres can be precisely aligned for the loads encountered in the sewer. Pipe liners made of GFRP can withstand extreme loads at very thin wall thicknesses and feature a low weight at the same time. With GFRP pipe liners all common sewer diameters, from round and oval profiles to special profiles, can be rehabilitated in smaller and even large diameters.

### Unsaturated polyester resins (Excerpt from the DIN 16946)

| Type | Glass transition temperature to 50 °C | Bending strength      |
|------|---------------------------------------|-----------------------|
| 1100 | above 70 °C                           | -                     |
| 1110 | above 70 °C                           | 70 N/mm <sup>2</sup>  |
| 1120 | above 70 °C                           | 110 N/mm <sup>2</sup> |
| 1130 | above 120 °C                          | 70 N/mm <sup>2</sup>  |
| 1140 | above 120 °C                          | 110 N/mm <sup>2</sup> |

### Glass fibre categories (Types of strengthening fibres)

E-glass: (E=electric) counts as standard fibre; approx. 90% market share  
 S-glass: (S=strength) fibre with increased chemical resistance  
 R-glass: (R=resistant) fibre with increased strength and durability  
 C-glass: (C=corrosion) fibre with especially high corrosion resistance  
 E-CR glass: (E-glass corrosion resistant) fibre with esp. high acid resistance and others

### Definition “glass fibre“:

Glass fibres are long thin fibres made of glass. During production they are drawn out of molten glass. Glass fibres are for instance used for glass-fibre reinforced plastics (GFRP). Today they are considered to be one of the most important construction materials because they are durable, weather and chemical resistant, and inflammable. They feature a high resilience module, which improves the mechanical characteristics of plastics.

The rehabilitation of all common sewer diameters is possible with Brandenburger GFRP pipe liners (three typical examples shown here).

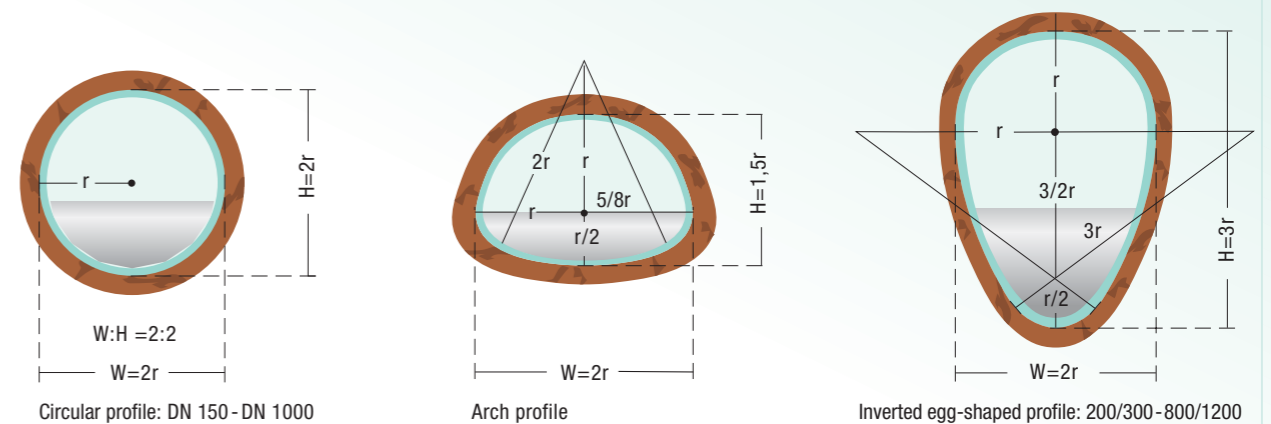

During the production of the Brandenburger GFRP pipe liner, the glass fibre is imbedded in a special vinyl or polyester resin thereby strengthening the mechanical properties of the plastic. Crucial for the longevity of the finished product is that the resin mixture and the glass quality used are perfectly tuned to one another in order to withstand the chemical and mechanical loads. That is why only high-grade resins (polyester resin pursuant DIN 18820 group 3, type 1140 or EN 13121 group 4 or vinylester resins pursuant DIN 18820 group 5, type 1310 or EN 13121 group 7A) and corrosion-resistant glass fibres, so-called E-CR glass fibres, are used for Brandenburger GFRP pipe liners.

The glass fibres are usually used as rovings (bundles of glass fibres), non-woven fabrics, clutches, mats, or as gauze. The tensile and pressure resistance of the glass fibre ensures a stiffening of the plastic while at the same time sustaining a certain flexibility.

Materials made of glass-fibre reinforced plastics (GFRP) play an important part in the aerospace industry, in the automotive industry, in pipeline construction, etc. They are usually employed as fibre composite materials. A composite material is a material that is made up of two or more combined materials that features other characteristics than its individual components. In GFRP pipe liners the glass fibres reinforce the resin component (matrix) in which they are imbedded. Contrary to that synthetic fibres (e.g. needled felt) are simply base material for the resin used.

With the patented seamless construction and the high glass-fibre share the Brandenburger GFRP pipe liner offers durability and best-possible mechanical strength. This even allows for applications in such cases where the old pipe is so damaged that the hardened Brandenburger pipe liner needs to take over the complete support function.

Conventional pipe liners consist otherwise of synthetic fibres, such as a polyester needled felt. This serves as a base material for the resin, but does not feature any re-enforcing characteristics. Thus GFRP pipe liners feature significantly better material characteristics based on their construction principle than pipe liners based on synthetic fibres (e.g. polyester fibre).

Glass-fibre reinforced plastics (GFRP) find employment where highest stability, excellent chemical durability, and extreme longevity are demanded of industrial materials.



# “Brandenburger GFRP Pipe Lining – outstanding material characteristics”



## Short-time modulus of elasticity

The most important basic mechanical features for application in the sewer rehabilitation are the bending modulus of elasticity (bending Young modulus) as well as the bending strength.

The bending Young modulus of a pipe liner is determined by the apex pressure trial. For the trial a stress deformation behaviour is simulated as it frequently occurs also under operational conditions in the sewer. The bending Young modulus states with how much resistance a material counters a load. The higher the bending Young modulus is the stiffer the material is.

With both short-time bending Young modulus of at least 7,500 N/mm<sup>2</sup> and 10,800 N/mm<sup>2</sup>, Brandenburger GFRP pipe liners feature outstanding mechanical characteristics that ensure high load stability and durability.

Highest load and stability

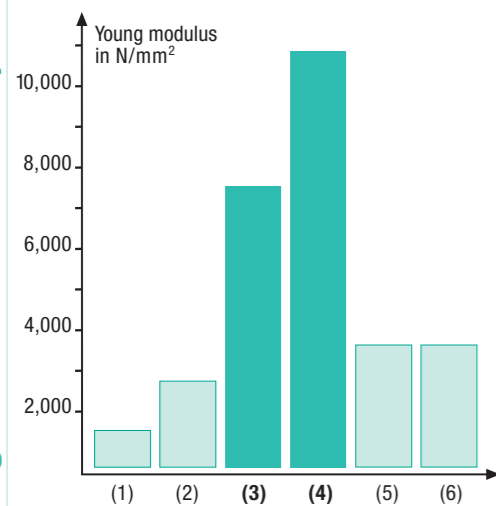

- (1): PE-HD 1,000 N/mm<sup>2</sup>
- (2): PVC 2,500 N/mm<sup>2</sup>
- (3): Brandenburger GFRP pipe liner 7,500 N/mm<sup>2</sup>**
- (4): Brandenburger GFRP pipe liner 10,800 N/mm<sup>2</sup>**
- (5): Synthetic fibre pipe liner 3,500 N/mm<sup>2</sup>
- (6): Polyester 3,500 N/mm<sup>2</sup>

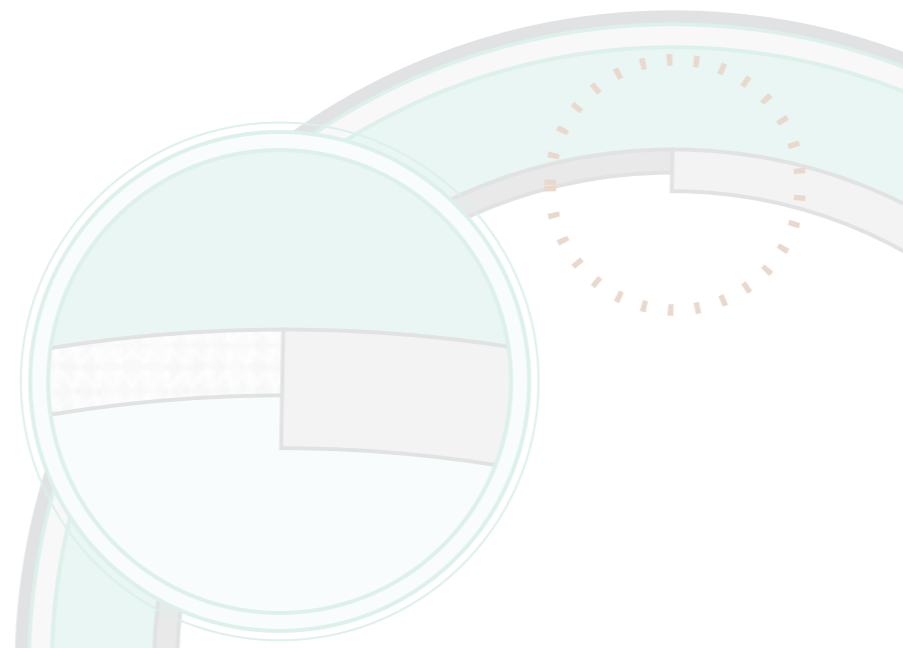

## The strongest GFRP pipe liner:

In November 2005 the thickest GFRP pipe liners in the world so far were installed by Brandenburger for the Hamburg water works to rehabilitate oval profile sewers. At segment lengths of 80 to 100 m the pipeliners had a weight of 8,000 kg to 10,000 kg. The curing speeds were at about 40–50 cm/minute. For test purposes the thickest yet manufactured GFRP pipe liner that was cured by UV light was accomplished by Brandenburger at a diameter of 1000 mm and a wall thickness of 28 mm.

## Long-time Young modulus

Information on the long-time bending modulus of elasticity is provided by the reduction factor for enduring loads. This value, determined during a 10,000-hour-long durability trial, takes note of the flow properties of the various materials and allows for a prediction of the behaviour after 50 years of permanent load.

GFRP pipe liners have a significantly lower reduction factor and therefore a higher long-time modulus of elasticity than synthetic fibre pipe liners (acc. ATV M 127 part 2) and can therefore be designed with significantly thinner wall thicknesses. The pipe diameter is reduced only slightly even at highest static requirements.

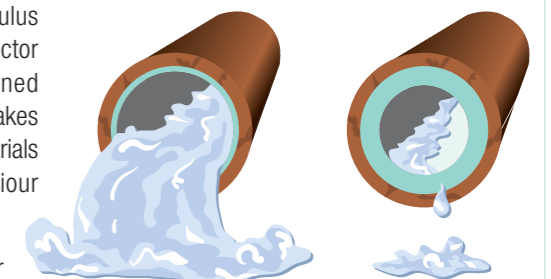

Sewers rehabilitated with Brandenburger GFRP pipe liners fulfil their tasks reliably at lesser wall thickness and can be written off as a long-term investment for municipal infrastructure for at least 50 years.

## Brandenburger pipe liner wall thicknesses

Old pipe condition II according ATV-M 127, Part 2 (01/2000), Groundwater level above (liner) invert = 3.0 m

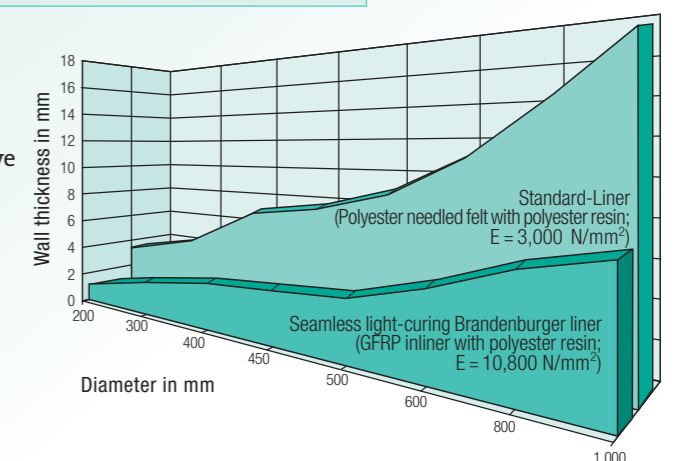

# “Brandenburger liner installation in practical application – with consistent high quality around the world”

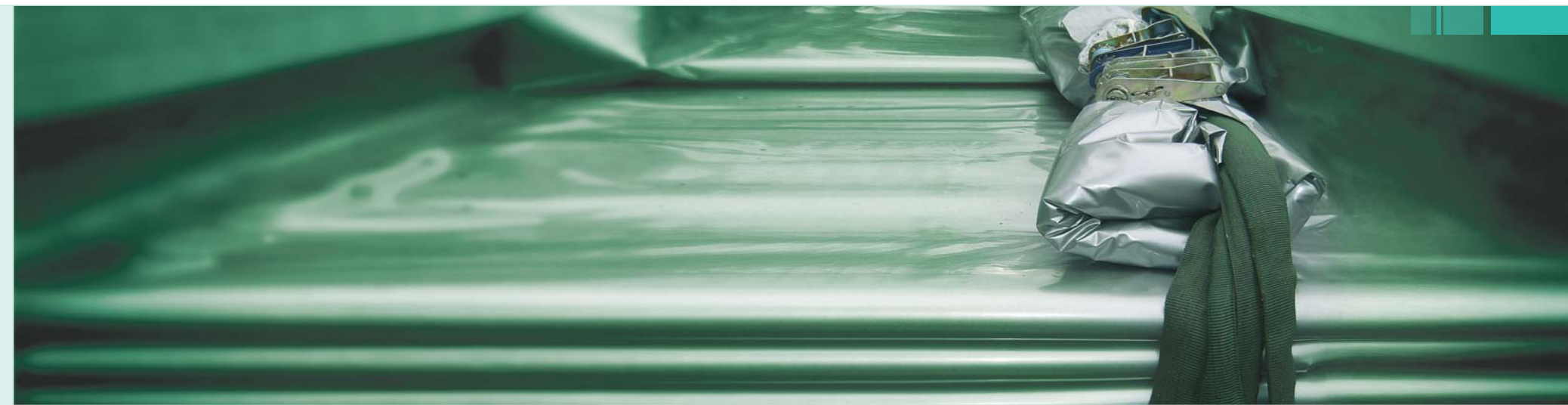

## GFRP pipe liner – Sound practical application

The GFRP material is impressive even during pipe liner installation. As it is drawn into the old pipe the longitudinal re-reinforcement made of glass fibre, whose tensile strength lies way above that of the liner's weight, takes up the longitudinal pull. This makes an overstretching or tearing of the GFRP pipe liner impossible.

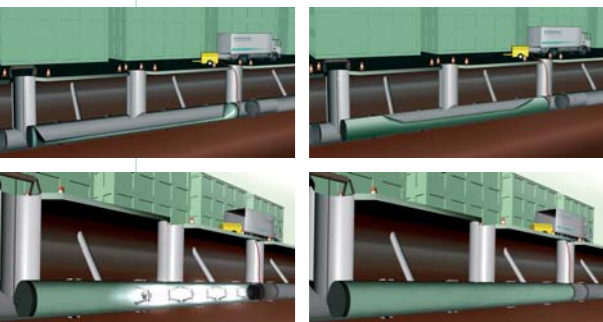

The internal foil that is needed for the pipe liners serves solely as an installation aid for GFRP pipe liners and is removed promptly after the curing. This makes it possible to carry out the leakage test right after the curing, which is the prerequisite for a durable and long-term rehabilitation.

Conversely to that, practically no leakage-proof of the actual pipe liner laminate can be made for some pipe liner systems with laminated internal foil. In a meanwhile applicable procedure (APS-Arbeitskreis Prüfinstitute Schlauchliner) the impermeability is first tested in a laboratory. It is only possible here to remove some sections, cut into the foil, and then to test these small material sections for impermeability. This equals the systematics of a sample test. A test of the entire liner on the other hand presents a 100% test and thus also carries much more significance. The test in the sewer itself has no significance for the aforementioned systems, because the test only can check the foil, but not the impermeability of the underlying pipe liner. In addition the internal foil can be damaged by the roughening by the cutting robot before the lateral branch connection, high-pressure rinsing, aging, as well as abrasion by sediments.

Current tests by independent inspection institutions on construction site samples have shown that Brandenburger GFRP pipe liners have excellent results not only in the leakage tests, but also for the achieved material characteristics (refer to: IKT-Liner Report 2003/2004, 2004/2005, 2006 and 2007: “Prüfergebnisse von der Baustelle” (Test results from the construction site), www.ikt.de).

## Drawing in with ease:

A new record has been established in mid-2008 by the production and installation of a pressure line liner DN 791: With a wall thickness of 11.2 mm and a length of 241 m, this liner weighed over 15 tonnes and was thereby the hitherto heaviest Brandenburger GFRP pipe liner that ever left the plant.

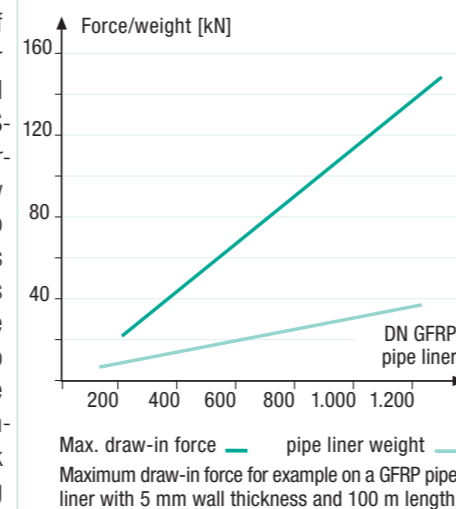

## Controlled stretch behaviour

Brandenburger GFRP pipe liner are light, stable, and yet superbly radial flexible. A specially developed glass fibre composite provides an extraordinary even stretching along the circumference. Thus it form-fits itself to the old pipe walls. Stretching in the longitudinal direction is prevented on the other hand by the special alignment of the glass fibre. Every Brandenburger GFRP pipe liner is produced undersized in the factory. This minimises the risk of creases forming at various old pipe deformations.

## Brief construction times – quick return to operation of the sewer

During rehabilitation with Brandenburger GFRP pipe liners the subsequent work can be carried out right after the curing; as opposed to synthetic fibre pipe liners. This includes the pipe liner connections in the two shafts as well as their opening and connection to the lateral inlets (e.g. with hat profile or compression technology). This is not possible with synthetic fibre pipe liner, because the shrinkage may take several days or weeks.

Since this subsequent work can be done immediately following the installation of the liner, the construction time is shortened and the sewer can be put back into operation quickly. This means significantly less interference for the local residents and less costs.

## Longest GFRP pipe liner:

In the Fall of 2004, at a length of 295 metres the currently longest pipe liner was installed and cured with UV light. The pipe liner DN 250, wall thickness 5 mm, weighed 2,300 kg total and was drawn in with a draw-in force of max. 700 kg.

Brandenburger GFRP pipe liners are expanded by pressurised air. Any water existing in the conduit or even in holes is displaced by the even expansion pressure. The new “pipe-in-a-pipe” attaches itself seamlessly to the old pipe wall.

## Durably sealed

According to DIN EN 1610 even the rehabilitated sewer section has to be sealed. In order for this requirement to be applied, the pipe liner has to be saturated in resin evenly and without many air pockets. This is ensured as best as possible by the preparation at the factory.

