

Brandenburger services for partner companies

In Germany and abroad: in order to ensure the liner's high level of certified quality, Brandenburger only cooperates with selected partners during rehabilitations. We are benefiting from many years of trustful cooperation with numerous partner companies, and we can continuously further develop the procedure on this foundation.

Brandenburger's partners: in shape for capable pipe lining

All Brandenburger partner companies perform the rehabilitation according to the manual, ranging from drawing in and curing to the relevant monitoring measures.

In doing so, they can rely on the support of Brandenburger:

- Technical services (project planning and consulting)
- Technical applications (project implementation / support)
- Training / advanced training on site (worldwide)
- Project support by a designated sewer rehabilitation crew for complex jobs in Germany and abroad



▲ Regular meetings with customers for exchange of information.



▲ Project support and training for our partners guarantee pipe lining on the highest level.

Brandenburger GFRP pipe liners are used worldwide:

- We have competent partners and a record of successfully implemented projects in Europe, Asia, North America, the Middle East and Australia.

Verifications of suitability for Brandenburger liners:	
Abrasion resistance (Darmstadt trough test)	DIN EN 295-3
Resistance against chemical attacks	DIN ISO 175
Stress crack corrosion	DIN EN 1120
Inspection for leakage construction site/laboratory	DIN EN 1610 / APS Guideline
3-point bending attempt dry	DIN EN ISO 178
3-point bending attempt damp	DIN EN ISO 899-2 combined with DIN EN 13566-4
High pressure flushing trial	Hamburg test, DIN 19523
Apex pressure trial (short-time)	DIN EN 1228
Apex pressure trial (long-time 10,000 h test)	DIN EN 761
Static proof	ATV M 127-2
Environmental safety	DIBt / ATV

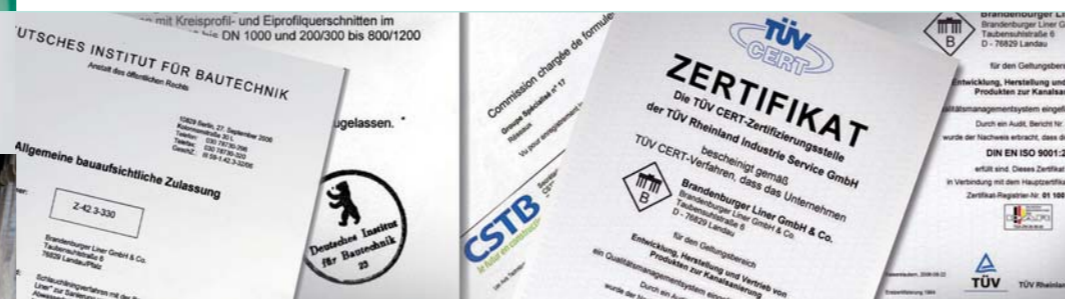

Seamless quality management – ranging from the selection of material to the construction site

Manufacturers and rehabilitation companies alike have an obligation towards quality assurance in trenchless rehabilitation. The Brandenburger quality management system seamlessly comprises the quality tests along the entire supply chain:

- in incoming goods
- in the production process (especially material retraceability, resin viscosity, resin content during the GFRP impregnation, electronic documentation of liner wall thickness and liner length)
- in the implementation of rehabilitation, including the construction site acceptance

The Brandenburger pipe lining and the UV light curing method developed for it have the necessary approvals and quality seals.

Certified quality

- DIN EN ISO 9001:2008
- Germany: DIBt approval no. Z-41.3-449
- EU: DIN EN 13566
- Switzerland: QuiK certificate of suitability no. 2004-12-4422-01
- France: CSTB technical certificate 17/06-182
- Denmark: NO DIG Kontrolordning for Ledningsrenovering (Inspection Regulation on Pipe Line Rehabilitation) No. B 1308
- as well as additional national approvals

Brandenburger CIPP Lining



Trenchless sewer rehabilitation with UV light-curing GFRP pipe liners

An established method for more than 25 years

The new **BB^{plus}** liner with an optimised surface structure:

- high level of resistance and durability
- high-grade materials
- easy handling
- short curing times

Our **plus** – your benefit!

Further questions about GFRP pipe lining from Brandenburger?

Please give us a call.

Brandenburger

Brandenburger Liner GmbH & Co. KG
 Taubensuhlstraße 6
 D - 76829 Landau/Pfalz
 Tel. +49 63 41 / 51 04-0
 Fax +49 63 41 / 51 04-155
 info@brandenburger.de

Safe renovation with GFRP pipe lining



Brandenburger has been a globally leading producer of high-tech materials used in a diverse array of industries for more than 70 years. Based on this experience, Brandenburger developed its seamless, light-curing GFRP pipe liner for the trenchless rehabilitation of wastewater sewers and canals at the beginning of the 1990s. Until this day, more than 3 million meters of Brandenburger liners have been successfully installed in approximately 30 countries.

Brandenburger pipe lining: Advantages of the trenchless rehabilitation

- Brandenburger pipe lining is more cost-effective and significantly faster than the installation of new pipes. Noise emissions and energy consumption are reduced – local residents and road users will be thankful.
- Brandenburger offers know-how from one source: liner material, UV light technology as well as user technology seamlessly interact within a closed system and ensure a high-quality curing on the construction site.
- The Glass-Fibre Reinforced Plastic (GFRP) developed by Brandenburger offers very good properties for sewer rehabilitation: better mechanical characteristics and less liner wall thickness than in conventional synthetic fibre liners ensure a stable finished product.

An overview of the Brandenburger ^{plus} liner:	
Nominal widths	DN 150 - 1000, oval profiles 200/300 – 800/1200
Profile	Circular, oval and special profiles
Wall thickness	3.5 mm - 12.6 mm, greater wall thickness on request
Installation lengths	up to max. 300 m (depending on the diameter)
Used fibreglass	Corrosion resistant Advantex® E-CR fibreglass
Used resins	Unsaturated polyester resins (UP resins) according to DIN 18820 group 3, A type 1140 or DIN EN 13121 group 4 or vinylester resins (VE resins) according to DIN 18820 group 5, type 1310 or DIN EN 13121 group 7A
Delivery form	impregnated, sealed UV lightproof, delivery straight to the construction site
Installation procedure	Pull-in method
Curing procedure	UV light curing, combination curing for great wall thickness

Exemplary profiles

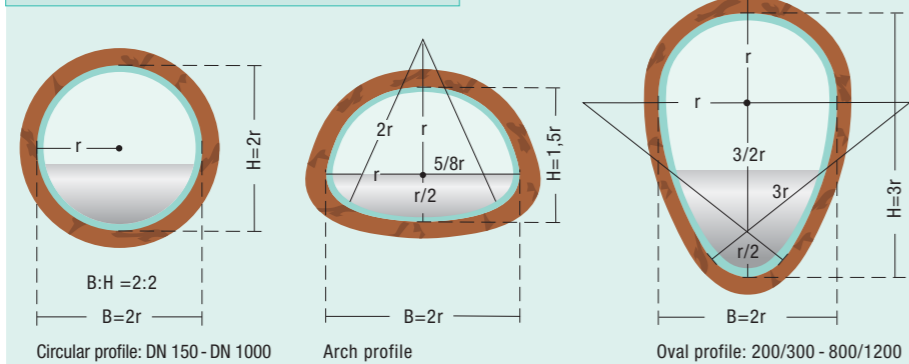

Brandenburger pipe liner wall thickness

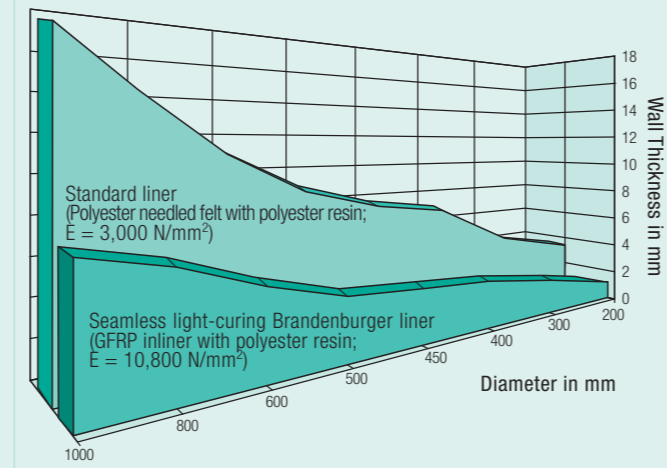

State of old pipe II according to ATV-M 127, part 2 (01/2000), centimetre of water over pipe base 3.0 m

GFRP pipe liner – Renovation with high-performance material

Stability, chemical resistance and longevity of the material used are decisive for a successful sewer rehabilitation. Therefore Brandenburger has been relying on glass-fibre reinforced plastic (GFRP) for decades.

Clever composites defy extreme loads

GFRP composite materials are ideal for the trenchless sewer rehabilitation: The Brandenburger GFRP pipe liners can be adjusted to the individual requirements in all conventional sewer crosssections. GFRP pipe liners are capable of bearing extreme loads at very low wall thickness.

The wrapping technology patented by Brandenburger is unique. Compared to conventional pipe liners a seamless design is ensured and offers special advantages:

- Even wall construction and constant wall thickness
- Constant stretch behaviour

Brandenburger wrapping technology

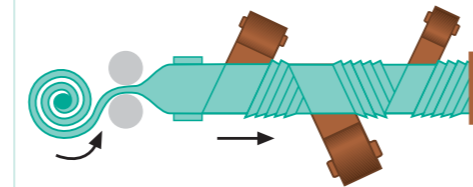

Mechanical characteristics Brandenburger GFRP pipe liner – BB^{plus}75 / BB^{plus}120

	BB ^{plus} 75	BB ^{plus} 120
Short-term tensile modulus in bending:	7,500 N/mm ²	10,800 N/mm ²
Short-term circumference tensile modulus:	8,500 N/mm ²	12,000 N/mm ²

*5%-quantile value

Fast, safe and durable: the pipe lining process

Construction: A cable winch pulls the Brandenburger liner from shaft to shaft into the sewer to be rehabilitated. Once it is in place it is sealed at both ends. Due to a special longitudinal reinforcement of glass fibres an overexpansion or tearing of the GFRP pipe liner is impossible.

Curing: The new "pipe within the pipe" is erected with compressed air until it is pressed form-fit to the wall of the old pipe. While retaining the constant internal pressure, the pipe liner is then cured using a movable high-speed UV light unit. The camera mounted on the light unit as well as temperature and pressure sensors ensure an exact process monitoring and documentation.

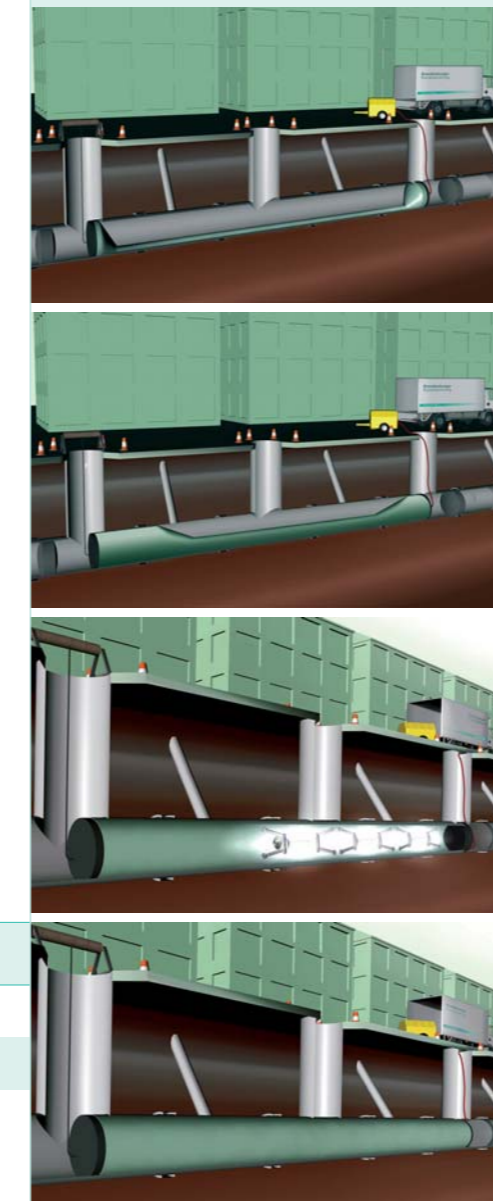

GFRP pipe lining in practice

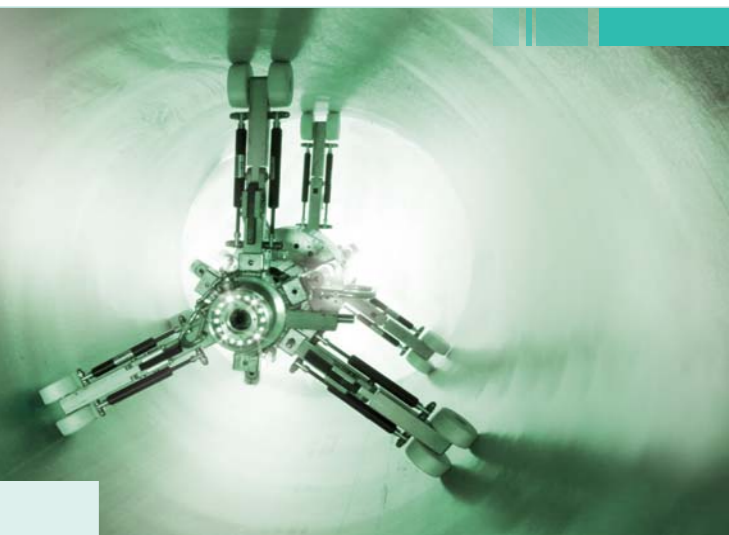

Recent tests that independent test institutes have carried out on construction site samples confirm that Brandenburger GFRP pipe liners achieve excellent results both in the leakage tests as well as in the achieved liner characteristics (see: IKT liner report; www.ikt.de).

sealed...

The impermeability can only be ensured in case of a homogenous resin distribution. For this reason, the Brandenburger GFRP pipe liner is impregnated on-site at the factory during a standardised and monitored procedure. There is no need to handle chemicals at the construction site.



form-fit...

Brandenburger GFRP pipe liners are superbly radial flexible due to the specially developed glass-fibre composite. Thus the pipe liner form-fits itself to the old pipe walls. Stretching in the longitudinal direction is prevented by the special alignment of the glass fibre.

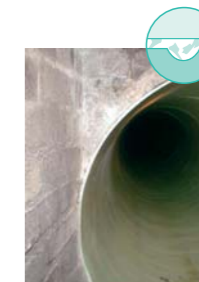

storage stability...

Due to the UV light-curing process the Brandenburger GFRP pipe liner can be stored and transported without difficulty. Packed UV proof into a transport box they are not sensitive to high temperatures and can even be shipped long distances.



and quick

Brandenburger GFRP pipe liners distinguish themselves by quick curing times. The project construction time is shortened, and the sewer can be commissioned for operation again more quickly. The local residents and traffic are less affected. Costs are kept down.



Only high-grade materials are used in Brandenburger GFRP pipe liners.



▲ The Brandenburger liner is produced ready for installation in the factory and is sealed UV lightproof.



▲ Afterwards, the liner boxes are delivered straight to the construction site.